



# POSTAGE PRICE GUIDE

## FOR STAMP CUSTOMERS

➤ *PRICES FOR OUR NEW, SIMPLER PRICING STRUCTURE*

EFFECTIVE 11 APRIL 2017



**T** 616616  
**E** [customerservices@jerseypost.com](mailto:customerservices@jerseypost.com)  
**W** [www.jerseypost.com](http://www.jerseypost.com)

**Jersey  
Post** 

# INTRODUCTION

## ➤ 2017 POSTAGE RATES

This guide contains the current standard postage and premium postage prices for customers who use stamps to pay for their service, or access our services over a post office counter or via an automated Post & Go machine.

Standard and premium postage services are available to purchase from any post office, but stamps for letters and large letter sized items being sent to local and UK, Isle of Man and other Channel Island addresses are also available to purchase from supermarkets, convenience stores, garages and card retailers.

## ➤ FURTHER INFORMATION

For further information or clarification on postage prices please visit [www.jerseypost.com/pricing](http://www.jerseypost.com/pricing). Alternatively, you can also contact our Customer Services team on **(01534) 616616** or via email at [customerservices@jerseypost.com](mailto:customerservices@jerseypost.com).

Business customers using an account or franking meter should contact our Business Sales team on **(01534) 616590** or email [business@jerseypost.com](mailto:business@jerseypost.com) for postage prices applying to their services.

# CONTENTS

OUR NEW, SIMPLER PRICING STRUCTURE	2	OTHER SERVICES	
POSTAGE SERVICES		<i>Redirection Service</i>	6
<i>Local Mail Services</i>	3	<i>Retention of Mail</i>	6
<i>UK, Isle of Man and other CI Mail Services</i>	3	<i>Unpaid and Underpaid Postage</i>	6
<i>European Mail Services</i>	3	<i>British Forces Post Office (BFPO)</i>	6
<i>Rest of World Mail Services</i>	3	<i>Articles for the Blind</i>	6
PREMIUM POSTAGE OPTIONS		<i>Poste Restante</i>	6
<i>Premium Choice Options</i>	4		
<i>Premium Cover Options</i>	5		
<i>Premium Express Options</i>	5		



# OUR NEW, SIMPLER PRICING STRUCTURE

Following customer feedback from our annual island-wide survey, we've simplified our postage service to make it easier for customers to choose the best option for sending their items.

We've rationalised the number of standard postage weight steps and adopted a consistent approach across all destination zones. We've also streamlined our premium postage options to more easily explain enhanced sending choices, and we've introduced a step-by-step approach that allows customers to build the service that best suits their needs.

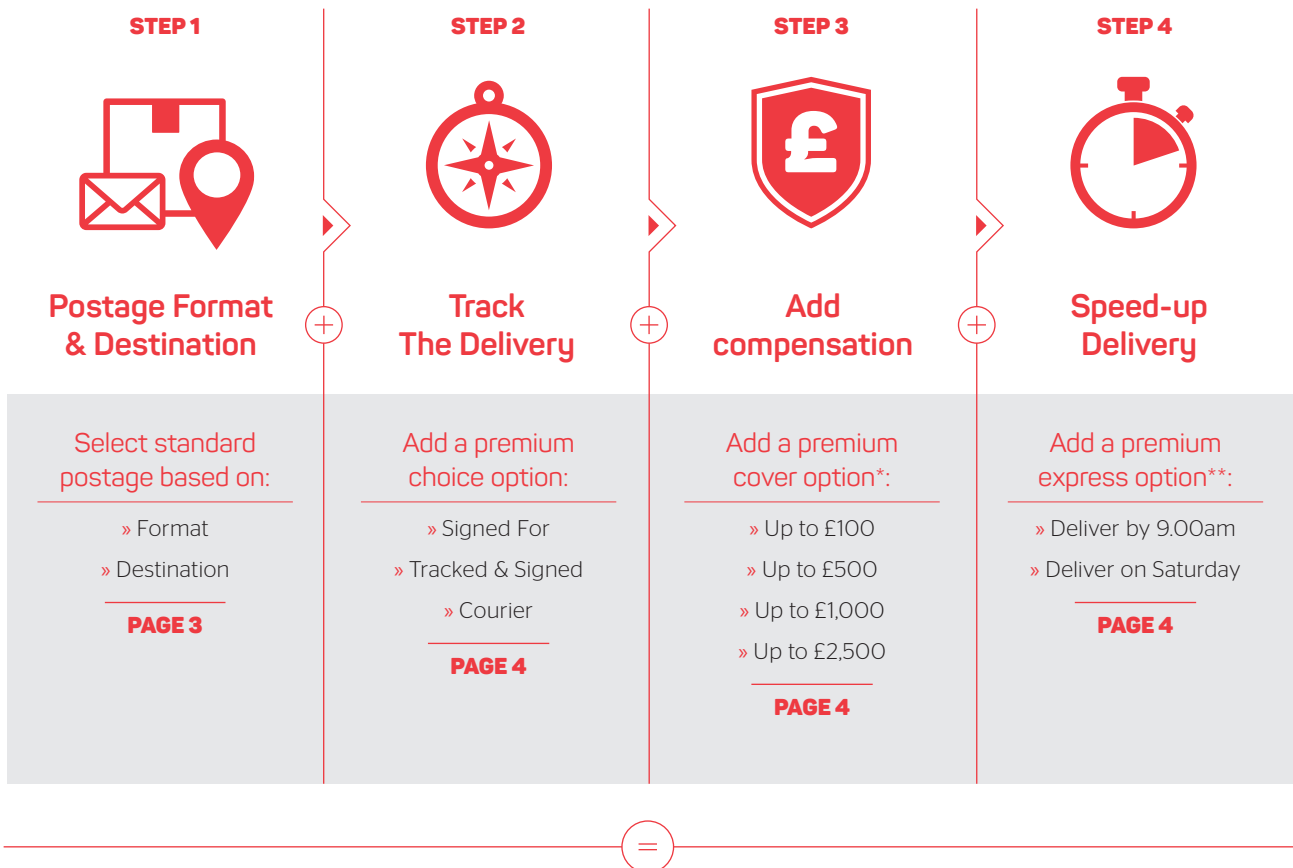

**Add together the prices for each of the required steps to reach the total postage price payable.**

\*Level of cover available dependent on destination. \*\*Express options available dependent on destination.

# POSTAGE SERVICES

## ➤ STEP 1 - STANDARD POSTAGE



Calculate the postage price for your item by selecting the correct format, weight step and destination from the table below.

MAIL FORMAT	WEIGHT (UP TO)	LOCAL	UK, IOM AND OTHER CI	EUROPE*	REST OF WORLD
<b>Letter</b>	<b>100g</b>	49p	63p	73p	90p
<b>Large letter</b>	<b>100g</b>	79p	£1.07	£1.32	£2.52
	<b>250g</b>	£1.13	£1.49	£2.54	£4.20
	<b>500g</b>	£1.58	£1.98	£4.40	£7.20
	<b>750g</b>	£1.98	£2.77	£6.60	£10.80
<b>Parcel</b>	<b>100g</b>	£1.01	£2.15	£2.49	£3.20
	<b>500g</b>	£1.55	£3.26	£4.98	£8.00
	<b>1kg</b>	£2.53	£5.24	£8.03	£12.80
	<b>1.5kg</b>	£3.79	£7.33	£12.05	£19.20
	<b>2kg</b>	£5.05	£8.00	£16.06	£25.60
<b>Large parcel*</b>	<b>5kg</b>	£6.85	£10.95	£35.60	£41.00
	<b>10kg</b>	£7.00	£11.25	£43.00	£59.00
	<b>20kg</b>	£7.15	£11.55	£58.00	£96.00
	<b>30kg</b>	£7.30	£12.25	£72.50	£132.00

\* For a full list of European destinations, please visit [www.jerseypost.com/pricing](http://www.jerseypost.com/pricing)

### PRODUCT SPECIFICATIONS

#### LETTER

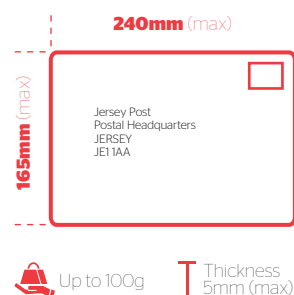

#### LARGE LETTER



#### PARCEL

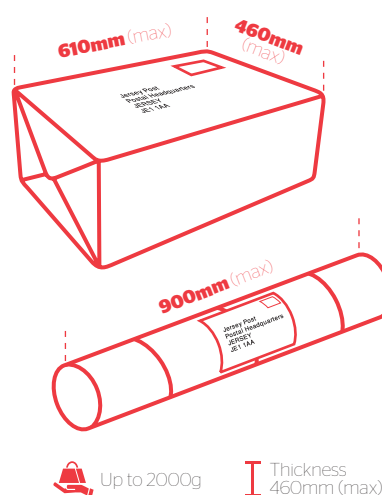

#### LARGE PARCEL

Any item that exceeds either the measurements or the weight of a parcel is classified as a large parcel.

\*Large parcels sent to the USA, Falkland Islands, Kiribati, Niger, Papua New Guinea, Tonga and Vanuatu incur a £1.00 per kilo sending supplement.

# PREMIUM POSTAGE OPTIONS

Whilst our standard postage service will get your mail item to its destination, there are occasions when only a premium choice will do.

You may want to know that your mail item arrived safely, for example, or track its progress until it reaches the destination. Some important items may need the personal attention of a dedicated courier service for additional security, or a level of compensation in the unlikely event of loss or damage. At other times, you may just want to get your item there faster.

Premium postage offers all of these options, in combination so that you can build the service that best suits your needs.

**For example:**

Sending a large letter of 400g to London that you want track through the postal network, check that it has arrived, ensure £500 compensation in the unlikely event it's lost or damaged, and want to it to arrive on Saturday instead of Monday:



## ➤ STEP 1 - SELECT STANDARD POSTAGE

Work out the standard postage price of sending your item using the table on page 3 of this booklet.

## ➤ STEP 2 - PREMIUM CHOICE OPTIONS

Select **Signed For** to check that an item has reached its destination - includes up to £30 of compensation in the unlikely event of loss or damage.

Select **Tracked & Signed** to track the progress of an item through the postal network and check that it has reached its destination - includes up to £100 of compensation in the unlikely event of loss or damage.

Select **Courier** to arrange the item's secure and speedy despatch and delivery through the dedicated network of FedEx, Jersey Post's global courier partner - includes up to £500 of compensation in the unlikely event of loss or damage.

DESTINATION	LOCAL	UK, IOM AND OTHER CI	EUROPE	REST OF WORLD
<b>Signed For</b>	£1.00	£2.00	£3.00	£4.00
<b>Tracked &amp; Signed</b>	£4.00	£5.00	£6.00	£7.00
<b>Courier</b>	Please see note 1			

Note 1 - for full details on our Courier services, please call Customer Services on 616616 or visit your local post office.



### ➤ STEP 3 - PREMIUM COVER OPTIONS

Is your item valuable? Enhance the level of compensation available for valuable items by adding additional cover.

LEVEL OF COVER	LOCAL	UK, IOM AND OTHER CI	EUROPE	REST OF WORLD
<b>Up to £100</b>	£1.00	£1.00	£1.00	£1.00
<b>Up to £500</b>	£2.00	£2.00	£2.00	N/A
<b>Up to £1,000</b>	£3.00	£3.00	N/A	N/A
<b>Up to £2,500</b>	£5.00	£5.00	N/A	N/A



### ➤ STEP 4 - PREMIUM EXPRESS OPTIONS

For **Tracked & Signed** items sent to local or UK, IoM and other CI addresses, you can increase their speed of delivery by choosing a premium express option:

- » Deliver by 09:00
- » Deliver on Saturday

Items to most European or Rest of World destinations can be sent using our Courier service in order to speed up delivery to the final destination. Please call Customer Services on 616616, or visit your local post office for more information on these services.

EXPRESS	LOCAL	UK, IOM AND OTHER CI	EUROPE	REST OF WORLD
<b>Deliver by 9.00am</b>	£4.00	£6.00	N/A	N/A
<b>Deliver on Saturday</b>	£2.00	£3.00	N/A	N/A
<b>Courier</b>	Please see note 1			

Note 1 - for full details on our Courier services, please call Customer Services on 616616 or visit your local post office.

## OTHER SERVICES

This section provides pricing information for all other post-related services.

### ➤ REDIRECTION SERVICE

	LOCAL	UK, IOM & OTHER CI	INTERNATIONAL**
1 month (ave. 20 days)	£26.00	£44.00	£72.00
3 months (ave. 60 days)	£44.00	£92.00	£147.00
6 months (ave. 120 days)	£68.00	£158.00	£271.00
12 months (ave. 240 days)	£105.00	£293.00	£455.00

### ➤ RETENTION OF MAIL

Retention of Mail	£25.00
-------------------	--------

Maximum duration from date service first initiated up to a maximum of two successive calendar months.

### ➤ UNPAID AND UNDERPAID POSTAGE

In addition to any discrepancy outstanding relating to the full cost of postage or any other fees for which the letter has become liable, a surcharge fee of **£1.20** shall be payable for each letter that is unpaid or underpaid.

### ➤ BRITISH FORCES POST OFFICE (BFPO)

Items weighing more than 2kg (excluding Signed For and International Signed For) are always charged at the UK, Isle of Man and other CI rate. Items weighing less than 2kg are posted free of charge.\*

### ➤ ARTICLES FOR THE BLIND

Free\*

### ➤ POSTE RESTANTE

Free\*

\*At the first weight step and subject to the terms set at the relevant postal scheme that can be obtained by writing to: The Company Secretary, Jersey Post limited, Postal Headquarters, JERSEY, JE1 1AA. \*\*European and Rest of World destinations.

 mail  
made  
simple 

**T** 616616

**E** [customerservices@jerseypost.com](mailto:customerservices@jerseypost.com)

**W** [www.jerseypost.com](http://www.jerseypost.com)

**Jersey  
Post** 