



Jersey Post's guide to addressing and packaging standards

August 2024



About this guide

It's in everyone's interest to ensure your Item of Mail gets delivered without mishap. The information contained in this guide sets-out the best practice approach to addressing items and the recommended way of packaging objects to minimise the risk of damage.

Contents

Mail formats	3
Addressing standards	4
Guidance on wrapping and packing individual objects	6
Top 10 tips for posting	9

Mail formats

Cards and documents

Letter



 Up to 100g

 Thickness 5mm (max)

Large letter



 Up to 750g*

 Thickness 20mm (max)

*Max weight for International large letter items is only up to 500g

Goods and merchandise

Parcel

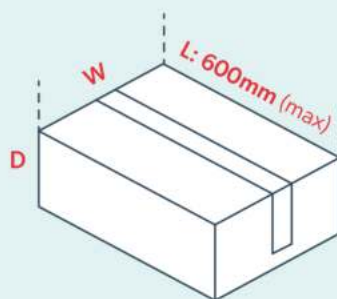

 Up to 2kg

Combined **L + W + D** | Up to 900mm

Large Parcel

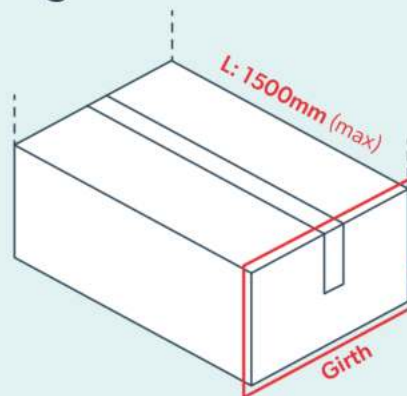

 Up to 30kg

Combined **Girth+Length** | Up to 3000mm

*Certain countries and territories limit Large Parcels to less than 20kg.

Addressing standards

Getting the address right on an item is crucial for the reliability of any postal service. While we will always try to get the mail through, we strongly recommend that you use the following standards when addressing your mail.

Example addresses

Here is an example of the best way to write a **Local address**:

Mr A Smith
Town View
Stopford Road
St Helier
JE2 4LB

Here is an example of the best way to write a **UK, Isle of Man or Other Channel Islands address**:

Miss P Jones
1 Castle Road
Heswall
Bournemouth
ENGLAND
BH1 1AA

Here is an example of the best way to write a **European or Rest of World address**:

Sr.C.Fernandez
Av das A'Augsa Livres
Monte Trigo
7220 Portel
PORTUGAL

Accuracy

Always use a full and accurate address that includes a town and a postcode. If in doubt, use our Postcode & Address Finder application at www.jerseypost.com.

Positioning

- Name and address go on the lower left corner of the front of the envelope or parcel
- Make sure there is a generous margin around the address
- Stick the correct postage stamp or label in the top right corner

Text

- If writing the address take time to use clear easy-to-read hand writing
- If printing the address use an easy-to-read font
- Left align the text
- Don't use commas or full stops

Colour

- Make sure that the ink stands out clearly against the colour of the envelope or parcel
- If using a coloured envelope, use a white label with black ink

Line order

Top lines

- Write or print the person or persons' name, including surname, on the first line, above the address
- Use a separate line if including the name of an organisation

Middle lines

- Use one line for the property number and street name
- If the property has a name, place on one line and drop the street name to the line below
- Use the next line for local area or village name
- Use the next line for the town name

Bottom lines

- Write the destination country
- Use the final line for a Jersey or UK postcode, in capital letters

Example

Return address A return address is an address we can send the mail back to, in case we are prevented from delivering it. Write the words 'return address' on the back of the envelope and underneath that, the actual return address.

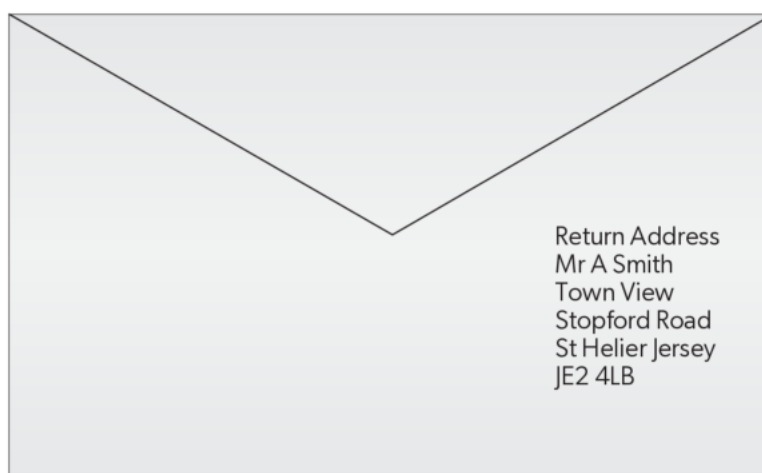
Example

Guidance on wrapping and packing individual objects

Alcoholic beverages

- Securely wrap using polythene with an absorbent material such as newspaper and cushioning material around each item to protect from breakage Seal inner packaging with tape to prevent any leakage if an item is broken
- Place in a rigid outer container and mark as 'FRAGILE' if sending glass bottles
- Make sure that the sender's name and return address is clearly visible on the outer packaging
- See our Guide to Prohibited and Restricted Goods for sending restrictions

Balloons containing 'non-flammable' gas

- Surround with cushioning material
- Place in a rigid outer container clearly marked 'NON-FLAMMABLE GAS'
- See our Guide to Prohibited and Restricted Goods for sending restrictions

Batteries (except those classified as dangerous goods)

You can send alkaline, nickel metal hydride (NiMH) or nickel cadmium (NiCd) batteries if they are new and contained in unopened their original packaging

You cannot send defective or damaged cells or batteries

You can only send lithium ion/polymer/metal/alloy batteries that are within an electronic device, but never in isolation.

Place any electronic device containing batteries in a strong rigid packaging, secured against movement, and packed to prevent accidental activation

Make sure that the sender's name and return address is clearly visible on the outer packaging

See our Guide to Prohibited and Restricted Goods for sending restrictions

Biological substances including diagnostic specimens

- May be sent by, or at the specific request of, a qualified medical practitioner, registered dental practitioner, veterinary surgeon, registered nurse or a recognised laboratory or institution
- The total sample volume/mass in any parcel should not exceed 50ml/50g
- Only permitted for destinations within the UK
- The sender's name and return address must be clearly visible on the outer packaging
- See our Guide to Prohibited and Restricted Goods for sending restrictions

Books

- Ensure that you include enough packaging to prevent damage to the binding and corners
- For small books consider using a padded envelop, for larger books consider a corrugated fibreboard book pack with 2.5cm clearance at each end

Cameras / projectors

- Detach any lens or additional pieces
- Consider using the original retailers packaging if possible, or a rigid container, ensuring that that you surround with adequate cushioning material

Cash or money

- Use a secure rigid container for coins, never an envelope
- Never write or indicate that the package contains cash or coins
- Never use clear or transparent packaging when sending cash

Christmas crackers

- Must only be sent in their original form in unopened original packaging

Computer disks, audio and DVDs and CDs

- Securely wrap in cushioning material
- Place in a rigid outer container ideally suited for this purpose
- Consider using purpose-made screened envelopes for computer disks

Drugs for medical or scientific purposes

- Can only be sent by medical practitioners in an emergency
- Ensure they are packed in a strong container
- Make sure that the sender's name and return address is clearly visible on the outer packaging
- See our Guide to Prohibited and Restricted Goods for sending restrictions

Electronic items - small items such as mobile phones, iPods, MP3, eBooks, sat navs, etc.

- Securely wrap each item individually in cushioning material, ensuring that any plugs pins are unable to damage the contents and outer packaging
- Pack any equipment containing cells or batteries in strong rigid packaging
- Do not send anything containing defective or damaged cells or batteries
- Secure equipment against movement, and pack to prevent accidental activation
- Make sure that the sender's name and return address is clearly visible on the outer packaging
- See our Prohibited and Restricted Guide for more information about sending electronic items

Electronic items - medium to large items, eg iPad or laptop

- Surround with sufficient amount of cushioning material to prevent damage from knocks and vibrations
- Remove and pack additional or loose parts separately
- Send in a strong, rigid outer container that is securely sealed to prevent anything falling out during transit
- See our Guide to Prohibited and Restricted Goods for sending restrictions

Fish, fruit, meat and other perishables

- Only send goods capable of withstanding a journey of up to 48 hours
- Use suitable inner packaging to prevent leakage
- Send in suitable container, a strong corrugated board box for example or purpose designed polystyrene pack, clearly labelled as 'PERISHABLE'
- Make sure that the sender's name and return address is clearly visible on the outer packaging

Flowers

- Only send goods capable of withstanding a journey of up to 48 hours
- Arrange in layers separated by tissue paper
- Use waterproof wrapping if including damp moss or phials of water
- Use suitable inner packaging to prevent leakage
- Send in suitable container, a strong corrugated board box for example or purpose designed polystyrene pack, clearly labelled as 'PERISHABLE'
- Make sure that the sender's name and return address is clearly visible on the outer packaging

Fragile items, eg glass, china, resin, etc.

- Wrap each item individually, surrounding each with a suitable layer of cushioning material
- Take care to wrap the extremities of any delicate item, i.e. limbs of figurines, carefully
- Send in suitable container, a strong corrugated board box for example or purpose designed polystyrene pack, clearly labelled as 'FRAGILE'

Keys

- Wrap in cardboard and place in a padded envelope
- Attach a label with a contact name and telephone number

Leaflets and brochures

- For items up-to-1cm in thickness use a padded bag, heavy-duty cardboard envelope or polythene shrink-wrap
- For items up-to-5cm thickness use a corrugated paper, thick paper or polythene shrink-wrap

Liquids and creams (no more than 1 litre in volume)

- Wrap in polythene, seal with tape and surround with absorbent material such as sawdust or newspaper
- Use a rigid leak-proof outer packaging such as fibreboard or polystyrene

Living creatures (e.g. insects and invertebrates)

- Certain living creatures can be sent by post, such as bees, caterpillars, cockroaches, crickets, destroyers of noxious pests, earthworms, fish fry and eggs, leeches and other parasites, lugworms, maggots, mealworms, pupae and chrysalides, rag worms, silkworms, spiders, stick insects and some other insects
- They must be boxed and packaged to protect the creatures, our staff and our customers from harm
- Clearly label any item as 'URGENT - LIVING CREATURES - HANDLE WITH CARE'
- Make sure that the sender's name and return address is clearly visible on the outer packaging
- See our Guide to Prohibited and Restricted Goods for sending restrictions

Magazines and newspapers

- Avoid folding or rolling the item
- For items up-to-1cm in thickness use a padded bag, heavy-duty cardboard envelope or polythene shrink-wrap
- For items up-to-5cm thickness use a corrugated paper, thick paper or polythene shrink-wrap

Magnets (e.g. in loudspeakers or magnetic media)

- Only send if the magnetic field strength is less than 0.159A/m at a distance of 2.1m from the outside of the package Avoid damage to other items such as discs or tapes by sending magnets separately
- Wrap in soft packing material and use strong outer packaging such as a corrugated board box or purpose designed polystyrene pack
- Make sure that the sender's name and return address is clearly visible on the outer packaging

Maps, plans and drawings

- Use rigid cardboard or plastic tube (maximum length 90cm)

Perfume (non-flammable or alcohol content less than 70%)

- Wrap in polythene, seal with tape and surround with absorbent material such as sawdust or newspaper
- Use a rigid leak-proof outer packaging such as fibreboard or polystyrene

Powders and fine grains (e.g. tea, coffee)

- Use a strong container such as strong polythene bag and seal securely with tape, then place inside a second container and seal again
- The double-wrapped item should be placed in a rigid corrugated box to prevent leakage
- Make sure that the sender's name and return address is clearly visible on the outer packaging

Prescription medicines and drugs sent for scientific or medical purposes that are not classified as dangerous goods (including but not limited to inhalers of a volume of 50ml or less)

- May be sent by, or at the specific request of, a qualified medical practitioner, registered dental practitioner, veterinary surgeon, registered nurse or a recognised laboratory or institution
- The medicines must be securely closed and placed in a leak proof liner such as a sealed polythene bag (for liquids) or a sift-proof container (for solids)
- Outer packaging - must be tightly packed in rigid outer packaging and must be secured or cushioned to prevent any damage to the medicines
- Make sure that the sender's name and return address is clearly visible on the outer packaging

Prints, frames and mounted canvas

- Wrap with sufficient cushioning material to protect item and place between thick board or polystyrene packaging
- If the item includes glass, increase the amount of cushioning material and treat as a fragile item

Prints (unframed)

- Wrap in tissue paper and place in a heavy duty cardboard envelope or if possible roll and send in a rigid tube
- Clearly mark package 'PHOTOGRAPHS - DO NOT BEND'

Records (vinyl discs)

- Wrap with sufficient cushioning material to protect item and place between thick board or polystyrene packaging
- Clearly mark package 'RECORDS - DO NOT BEND'

Scissors, knives and other sharp items

- Wrap heavy cardboard around all sharp edges and points, strong enough to ensure that the contents do not pierce the outer packaging before wrapping each item with cushioning material
- Place in a suitable outer container such as a padded envelope
- Make sure that the sender's name and return address is clearly visible on the outer packaging

Water-based paints, wood stains and enamels

- Volume per item should not exceed 150ml
- Wrap in polythene and seal with tape to ensure that any leakage is contained within the outer packaging
- Surround with absorbent material such as newspaper and sufficient cushioning material to protect each item from damage
- Surround with cushioning material and place in a suitable rigid outer container
- Make sure that the sender's name and return address is clearly visible on the outer packaging
- See our Guide to Prohibited and Restricted Goods for sending restrictions

Top 10 packaging tips

We take great care in our deliveries, but there are some things you can do to help us ensure your items are delivered safely. We have compiled a list of top tips you can do to ensure your package is protected through transit properly.

1. Use high quality, strong cardboard boxes or added envelopes where possible to reduce the risk of your items being damaged during transit.
2. Ensure fragile items do not touch the sides of the packaging by using suitable padding, such as bubble wrap or crumpled paper, so that the item can not move within the box.
3. If you're sending a small item, such as a fridge magnet or USB pen, we advise using a small jiffy or polyethene bag to help ensure your item doesn't get sorted through the letter sorting machine.
4. Never use soft cases or jiffy bags to send fragile items.
5. We advise using recycled packaging where possible however, please avoid re-using boxes that have lost their strength.
6. Use strong parcel or vinyl tape on all side that open when securing your packages.
7. When sending important paper items, such as certificates or art prints, use a tube or strong cardboard packing to prevent the item being creased or bent in transit.
8. Make sure your labels are securely attached to your package.
9. When securing your label, make sure the barcode and address information is not covered and is clearly visible.
10. Write a return address on the back of the package, including a name and a telephone number.

